

# Advanced Bank locker system using RFID and GSM Technology

<sup>1</sup>Manoj N G, <sup>2</sup>Sohail Maidargi, <sup>3</sup>Vedaraj V Shetti, <sup>4</sup>Veerendra S Maradur, <sup>5</sup>Kavitha S S

<sup>1,2,3,4</sup>student in ECE department, NIE Mysuru, Karnataka, India 570008.

<sup>5</sup>Assistant professor in ECE department, NIE Mysuru, Karnataka, India 570008.

<sup>1</sup>(jnv.ngmanoj02@gmail.com)

<sup>2</sup>(Sohailmaidargirici@gmail.com)

<sup>3</sup>(vs.vedaraj1000@gmail.com)

<sup>4</sup>(veerendrasm1512@gmail.com)

<sup>5</sup>(kavithaece@nie.ac.in)

**Abstract --** The main objective of this paper is to design and implement a secure advanced bank locker system based on RFID and GSM technology which can be organized in banks, offices or even in homes. In this designed project the authenticated person can only recover the thing present inside the locker. The traditional locker systems using mechanical and key mechanism are replaced by new advanced techniques of locking system. These techniques are an integration of mechanical and electronic devices and are highly intelligent, simple and high efficiency. Here, we have implemented bank security system consisting of door lock system based on RFID and GSM which can activate, authenticate, and validate the user and give the access for the door in real time. This system consists of a microcontroller, RFID and its reader, lcd display, keyboard, GSM module and a relay. The main advantage of using passive RFID and GSM is for two step authentication and to make system more secure than the others. On other hand it also has advantage of generating real time password. In this system, the RFID reader reads the id number from passive tag and later it will be checked by the microcontroller, if id number matches it sends a message to the registered phone number to generate a password in the real time. Then it will provide you an option to enter the generated password on the keyboard present at the locker. If both password matches the door will get unlocked otherwise it denies the access and the user cannot make further use of locker.

**Keywords:** GSM, locking system, Microcontroller, RFID, two-step authentication.

## I. INTRODUCTION

In this 21<sup>st</sup> century, a digital age where safety and security has become an essential issue for many people all over the world both in urban and rural. There are people always who tries to steal something from somebody. To overcome this problem most of them use a lot of security items and alarm systems.

We can find varieties of alarm system in the market which senses the changes in the environment with the help of sensors available and gives information to users in various mode. But getting information while theft is taking place or already took is not a great option for all the time.

So, in this paper we designed a safety bank locker which can be also applicable on doors of house and office and so on with the help of GSM and RFID technologies for more security. This allows only authorized persons on radio frequency identification (RFID) based access control along with global system for mobile communication (GSM) technology.

Basically, an RFID system consists of an antenna or coil, a transceiver and a transponder (RF tag). The passive tags are less

expensive and lighter compared to the active tags whereas GSM is a globally accepted standard for digital cellular communication. GSM is a common European mobile telephone standard for a mobile cellular radio system operation at 900MHz. In this system we use GSM SIM800A module is used. It delivers voice, data and fax in form of small factor with low power consumption.

## II. RELATED WORKS

This section contains some of the related works with GSM monitoring and RFID usage.

In paper [1], this system is used to control home appliance tenuously and offer security when the owner is away from the place. The similar work presented in paper [2] which designed and developed a smart home application system. The system allows the property owner to be able to monitor and control the residence appliances via a mobile phone set by sending commands in the form of SMS messages and receiving the home appliances status.

In paper [3] and [4], it projects Zigbee-GSM based Monitoring and Remote-Control System. In these systems used both Zigbee and GSM for communicating between user and devices. This system allows user to monitor and control devices in the home through a number of controls, including a Zigbee based remote control. Users may remotely monitor and control their home devices using GSM. In paper [5], one more approach using GSM technology to communicate with the remote devices via SMS is remote metering system, in this paper illustrates a technique for remotely reading electricity meter readings using SMS.

Design used in paper [6] has a Prepaid Water Meter System for prepaid billing of water consumption through remote monitoring without any human involvement. This system may be fast and accurate billing of water as well as preventing any mishandling of it. However, paper [7] developed a water meter reading using GSM system that suitable for remote places to monitor the water meter reading before any billing process. This could reduce the use of human resource for reading the meter and issuing a bill. There was also a work on monitoring of electrical meter reading using GSM network done in paper [8]. The system was able of monitoring the meter reading and sent an SMS to the official center for billing purpose. This could reduce the number of estimated reading when the empower person unable to reach the meter.

### III. PROPOSED METHOD

In this proposed method, at first, the RFID reader reads the data from RFID tag and send it to the microcontroller, if the card is registered with the bank, then microcontroller display the account holder name and number otherwise it shows no register found. Then microcontroller sends SMS to registered mobile number of users for real time password generation. Now the user has to send the newly generated password to microcontroller using GSM. After receiving password from user through GSM the system asks user to enter the same password manually through the keyboard, if both passwords match the system will allow the user to access his locker or denies access if it doesn't match and it will send warning message to the registered user mobile number. This system is simple as there is no need to remember the password and more secured as there is no involvement of third party like in traditional locker system.

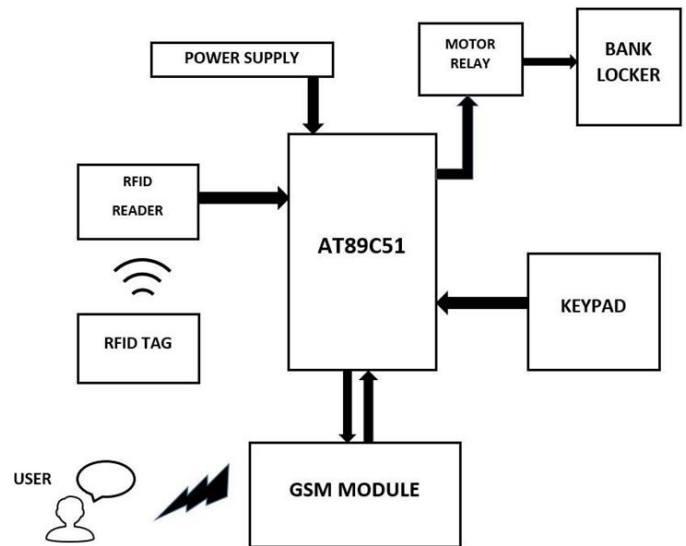

Fig1. Block diagram of bank locker system

#### A. Comparative study of existing and proposed locker system

Sl.no	Existing system	Proposed system
1.	RFID technology is used	Both RFID and GSM technology is used
2.	One password is referred	Two password is verified
3.	password is constant	real time password, no need to remember password.
4.	May be in Secured due to robbery of RFID and password	More secured due to double password verification.

#### B. Block diagram

Fig1. Shows the block diagram of bank locker system based on RFID and GSM technology. It consists of power supply section, keyboard, RFID Reader, AT89S51 microcontroller, MAX232driver, relay driver and GSM modem, LCD. The GSM board has a valid SIM card with sufficient recharge amount to make outgoing calls. The circuit is powered by regulated +5v dc.

#### C. Table of specifications.

Component	Specifications	Usage
AT89S51 Microcontroller	<ul style="list-style-type: none"> <li>4K Bytes of In-System Programmable (ISP)</li> <li>Flash Memory -Endurance:10,000 Write/Erase Cycles.</li> <li>OV to 5V operating range.</li> <li>Fully Static Operation:0 Hz to 33 MHz</li> <li>Three-level Program Memory Lock.</li> <li>128 x 8-bit Internal RAM.</li> </ul>	To store the overall program of the system and to process and coordinate between the different modules and components.
LCD LM016L Display	<ul style="list-style-type: none"> <li>Functions: 16-character x 2 lines.</li> <li>Display color: LM016L: Gray.</li> </ul>	For guiding the user through the process and display the commands.
RFID	<ul style="list-style-type: none"> <li>Operating voltage of EM-18: +4.5V to +5.5V.</li> <li>Current consumption:50mA.</li> <li>Can operate on LOW power.</li> <li>Operating temperature: 0°C to +80°C.</li> <li>Operating frequency: 125KHz.</li> <li>Communication parameter:9600bps.</li> <li>Reading distance: 10 cm, depending on TAG.</li> </ul>	To verify the user's RFID tag and send ID number to the microcontroller.
RFID Tags	<ul style="list-style-type: none"> <li>Passive tags.</li> <li>Dimension: 85mm.54mm.0.8mm</li> </ul>	RFID tags are given to each user and are used for verification.
Keypad	<ul style="list-style-type: none"> <li>Operating Voltage (V): 12 DC</li> <li>Operation temperature: 20 to plus 40 degrees Celsius.</li> <li>Life expectancy: 1 million closures.</li> </ul>	To get the key from user by typing manually.
L293D Motor Driver IC	<ul style="list-style-type: none"> <li>Speed and Direction control is possible.</li> <li>Motor voltage Vcc2 (Vs): 4.5V to 36V</li> <li>Maximum Peak motor current: 1.2A.</li> </ul>	To simulate the opening of locker by converting the voltage from 5 to 12.
GSM sim 800A module	<ul style="list-style-type: none"> <li>Quad-band 850/900/1800/1900 MHz.</li> <li>5V interface for direct communication with MCU kit.</li> <li>Built-in SIM Cardholder.</li> </ul>	To interact with user registered mobile and microcontroller by sending and receiving messages.
DC motor	<ul style="list-style-type: none"> <li>Nominal Voltage (VDC) 6</li> <li>Voltage Range (VDC) 3-12</li> <li>Current @ Max. Efficiency (A) 0.28</li> <li>Speed @MAX. Efficiency (RPM) 4260</li> </ul>	To display the opening and closing of locker door

**IV. SOFTWARE AND HARDWARE SETUP**

**A. Software circuit diagram**

Port 1 of AT89S51 is connected to the LCD display. i.e., LCD Pins D0 to D7 is connected to P2.4 to P2.7 and pins reset and enable pin of LCD is connected to Port 0.1 and Port 0.2 of Microcontroller respectively. Keypad of matrix 4\*3 is connected Port 1 of Microcontroller whereas for GSM module Interfacing TX, RX pin of GSM module is connected to serial ports of microcontroller, i.e., RX pin and TX pin respectively. RFID Receiver Module's TX pin is connected to serial input port RX i.e., port 3.0 of Microcontroller. For Simulation of Locker Operation. We are using a 5V DC motor It is connected with a help of Motor Driver. Port 3.4 and 3.5 of Microcontroller pins are used to connect IN pins of the Motor Driver and its OUT pins are connected to DC Motor pins. Connections are shown in the figure II given below. The proposed system is designed in proteus software using the inbuilt modules. The software program is written in embedded C

**B. Hardware circuit diagram**

The hardware interface has been made just as shown in the software circuit diagram during simulation. The power supply has been given through 12V adapter to microcontroller board, GSM and motor relay. We used LCD in 4bit mode interfacing with 4 pins of port2 or assembly language and compiled using Keil software. After compiler operation the hex code is generated and stored in the computer. The hex code of the program is burnt into the AT89S51 microcontroller by using proteus software.

Keypad is interfaced with port1. RFID and GSM's TX connected to RX with a two-way switch and GSM's RX to TX of microcontroller. The 12v motor is connected through L293D motor driver to microcontroller 3.4 and 3.5 ports.

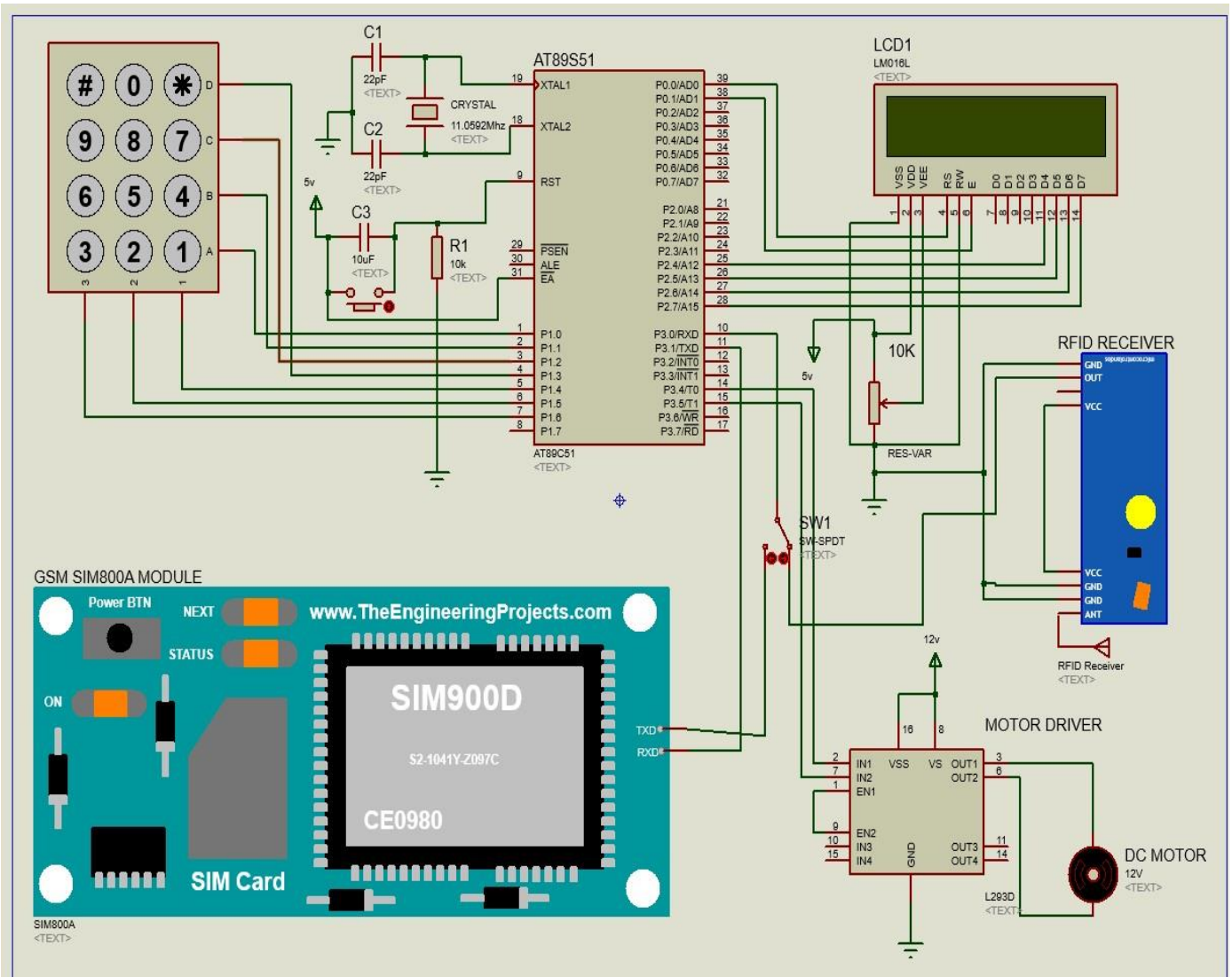

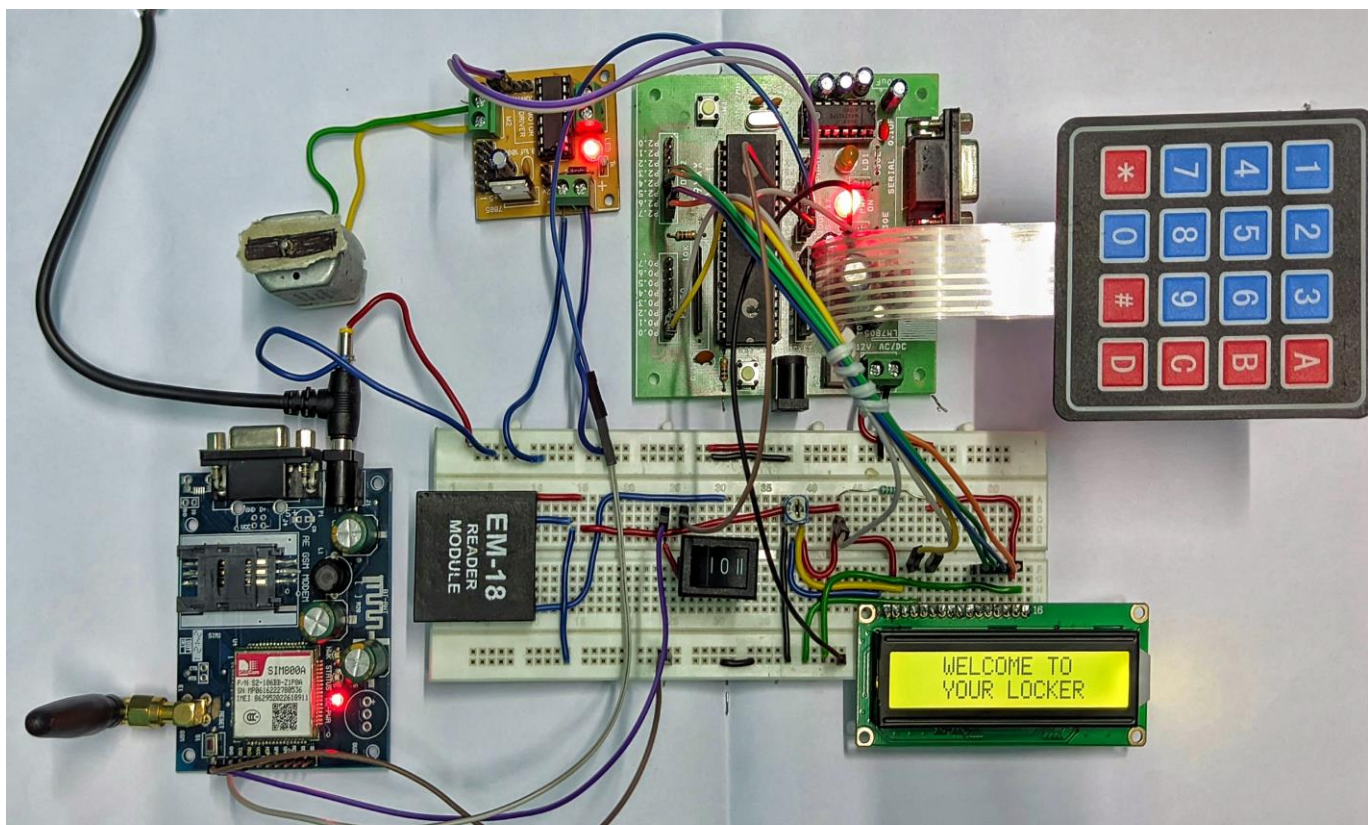

*FigIII.hardware implementation of bank locker system*

## V.RESULTS AND ANALYSIS

The output of both software simulation and hardware interface are found to be same. As expected, the RFID gives control to microcontroller by reading the cards and it is found efficient and fast when we use delay with the while loop. the motor driver converted the positive signs that is when both passwords matched to 12v as output to drive the motor. The use of 4\*3 keypad gives more combination of password instead of 3\*3 keypad. The GSM is found efficient as it sends and receives messages throughout the world and LCD as it is easy to interface. Analyzing with the other models it is found more securable as it used two step authentication and GSM technology along with RFID technology.

## VI. CONCLUSIONS

We have proposed and implemented a Bank locker security system using passive RFID and GSM which is a low cost and low in power conception design, compact in size and standalone system. The microcontroller compares the passwords generated by the user in real time through GSM and entered by keyboard mobile phone. If these passwords are correct the microcontroller provides necessary control signal to open the bank locker. Warning messages will be sent when number of access attempts are exceeded. Future work of this paper, is planned to a develop security system based on 3G camera for visual identification of the person and can make to block the further attempts for the user upon multiple attempts.

## REFERENCES

- [1] Malik Sikandar Hayat Khiyal, Aihab Khan, and ErumShehzadi. "SMS Based Wireless Home Appliance Control System (HACS) for Automating Appliances and Security", Issues in Informing Science and Information Technology. Vol. 9. pp. 887 – 894. 2009.
- [2] Al-Ali, A.R. Rousan, M.A. Mohandes, M. "GSM-Based Wireless Home Appliances Monitoring & Control System", Proceedings of International Conference on Information and Communication Technologies: From Theory to Applications,pp 237-238, 2004.
- [3] Carelin Felix and I. Jacob Raglend, "Home Automation Using GSM", Proceedings of 2011 International Conference on Signal Processing, Communication, Computing and Networking Technologies, pp. 15-19, 2011.
- [4]Ahmad A.W., Jan N., Iqbal S. and Lee C., "Implementation of ZigBee-GSM based home security monitoring and remote-control system", IEEE 54th International Midwest Symposium on Circuits and Systems (MWSCAS), 2011, pp. 1-4.
- [5] Md. Wasi-ur-Rahman, Mohammad Tanvir Rahman, Tareq Hasan Khan and S.M. Lutful Kabir, "Design of an Intelligent SMS based Remote Metering System", Proceedings of the IEEE International [3] Conference on Information and Automation, 2009, pp. 1040-1043
- [6] Islam, N.S. Wasi-ur-Rahman, M. "An intelligent SMSbased remote Water Metering System". 12thInternational Conference on Computers and InformationTechnology, 2009, 21-23 Dec. 2009, Dhaka, Bangladesh.
- [7] Mohd Helmy Abd Wahab, Siti Zarina Mohd Muji, FazlizaMd.

- Nazir. "Integrated Billing System through GSM Network". In Proceeding of 3rd International Conference on Robotics, Vision, Information and Signal Processing 2007 (ROVISP2007), Penang, 28 – 30 November 2007
- [8] Mohd Helmy Abd Wahab, Azhar Ismail, Ayob Johari and Herdawatie Abdul Kadir. "SMS-Based Electrical Meter Reading". In Proceeding of International Conference on Rural Information and Communication Technology 2009 (r- ICT), 17 – 18 June 2009, Bandung, Indonesia.
- [9] Parvathy A, Venkata Rohit Raj, Venumadhav, Manikanta, "RFID Based Exam Hall Maintenance System", IJCA Special Issue on "Artificial Intelligence Techniques - Novel Approaches & Practical Applications" AIT, 2011 .
- [10] Gyanendra K Verma, Pawan Tripathi, "A Digital Security System with Door Lock System Using RFID Technology", International Journal of Computer Applications (IJCA) (0975 – 8887), Volume 5– No.11, August 2010
- [11] Kumar Chaturvedula .U.P, "RFID Based Embedded System for Vehicle Tracking and Prevention of Road Accidents", International Journal of Engineering Research & Technology (IJERT) , Vol. 1 Issue 6, August – 2012, ISSN: 2278-0181
- [12] <https://www.arduino.cc/en/software>
- [13] <https://datasheetspdf.com/pdf/130695/ATMELCorporation/AT89S51/1>
- [14] <https://www.electronicwings.com/8051/rfid-reader-em18-interface-with-8051>
- [15] <https://lastminuteengineers.com/1293d-dc-motor-arduino-tutorial/>
- [16] <https://www.electronicshub.org/gsm-interfacing-8051-microcontroller/#:~:text=GSM%20Interfacing%20with%208051%20Microcontroller%20Circuit%20Principle%3A,-The%20main%20principle&text=The%20microcontroller%20used%20is%20AT89C51,to%20perform%20the%20required%20operation.>
- [17] <https://circuitdigest.com/microcontroller-projects/lcd-interfacing-with-8051-microcontroller-89s52>
- [18] <https://www.youtube.com/channel/UCukf-O0tNRyutgcBjjTc7DQ>
- [19] <https://www.electronicshub.org/8051-microcontroller-assembly-language-programming/>
- [20] <https://proteus.soft112.com/>
- [21] [https://www.researchgate.net/figure/RFID-interfacing-using-Virtual-Terminal-The-fig9-above-shows-the-Proteus-Simulation-of\\_fig7\\_334576905](https://www.researchgate.net/figure/RFID-interfacing-using-Virtual-Terminal-The-fig9-above-shows-the-Proteus-Simulation-of_fig7_334576905)